

# Windlass Sirius Installation Instructions

Virgin Rigid Plank – 100% Ortho Phthalate Free



## Attention

Before starting installation, read all instructions in entirety. Installation instructions must be followed in entirety for warranties to be considered valid. Pre-inspect the job site prior to delivery of the Windlass flooring. It is the responsibility of the owner and installer to ensure that the structure is suitable for the installation of luxury vinyl plank flooring using the following guidelines. Windlass Flooring is not responsible for flooring failure due to unsatisfactory job site and/or subfloor conditions. If any questions arise, please consult your Windlass flooring dealer.

## General Guidelines

1. **Installation:** Windlass flooring is only suitable for floating installation.
2. **Best Visual Look:** Windlass flooring replicates the look of a natural flooring product which has innate variations in color, sheen, and texture. Please pull from various cartons during installation and be careful not to install similar planks near each other so as to ensure best possible visible effect.
3. **Weather Tight:** Roofing and the exterior of the structure must be finished and weather tight with doors and windows installed. Windlass cannot be held responsible for job site conditions.
4. **Moisture:** Even though Windlass flooring is waterproof, it is not a moisture barrier. We **require** installing a moisture barrier, specifically a 6-8 mil poly sheeting under the Windlass flooring over a concrete subfloor **or** the use of 2 coats of Wakol PU280 moisture barrier on top of the concrete for on or above grade applications. Care should be exercised in order to ensure that there is NOT a moisture issue within the structure or any moisture intrusion from any source prior to installation. Windlass flooring does not warrant against damage, environmental, or structural from the effects of moisture intrusion from any source. All concrete, masonry, plastering, and other “wet” work must be complete and thoroughly dry. Concrete must be cured and tested for moisture. Painting of walls should be complete with the exception of the final coat on base moldings. Moisture content of subfloor should not vary more than 4% MC from the top of the subfloor to the bottom. Moisture content of wood subfloor should not exceed 12%. Moisture emission from concrete subfloor should not exceed 5 lbs per 1,000 square feet per 24 hrs as measured using calcium chloride test or 85% on RH test.
5. **Crawl Space Ventilation:** Crawl spaces must be a minimum of 18” from the ground to the underside of the joists. Crawl space earth (or thin concrete foundation slab) should be 100% covered by a vapor retarder of black polyethylene film (minimum 6 mil) or any recommended puncture resistance membrane, such as Class C meeting ASTM D1745. Joists must be lapped 6” and sealed with moisture resistant tape. The crawl space should have proper perimeter venting. Size of available vents should be equal to a minimum of 1.5% of the square footage of the crawl space. The vents should be located to provide for optimal cross ventilation. Proper ventilation is required in a non-conditioned crawl space. If crawl space is conditioned appropriately, ventilation in the crawl space is not required. Check local building codes for additional requirements. Relative humidity of crawl space should be consistent with interior of home.
6. **Basements:** Basements should be weather tight and have appropriate drainage systems in place. Rain gutters must be in place to carry moisture away from the structure. Humidity in basements must be controlled to prevent mold and damage to structure and vinyl flooring. Basement walls should be free of cracks and excessive moisture. Basement windows must have drains near them. Landscape irrigation systems and sprinklers should be directed away from the foundation. Drip irrigation systems for plant beds near structure are recommended.
7. **Climate Control:** Structure must have working climate control operating. To ensure proper performance of the floor, climate control at the job site should be maintained with the room temperature between 60-75 degrees Fahrenheit and relative humidity within 30-50% before, during, and after installation. These conditions must be maintained for at least 7 days prior to installation. Do NOT install Windlass flooring where it will be exposed to temperatures in excess of 140 degrees Fahrenheit.

8. **Storage and Handling:** Do NOT store flooring where there is no climate control. Make sure job conditions are right before delivering flooring. Flooring should not be delivered until exterior shell of house including roof is completed and house is weather tight with all windows and doors are in place. All cement work including concrete slab, plastering, painting, and all other “wet” work must be completed and thoroughly dry except for final coat on base molding. Store flooring only in a dry climate-controlled environment. Provide at least 4” of space underneath boxes of stored flooring to allow for proper air movement. Avoid prolonged exposure to direct sunlight as this can cause expansion and discoloration.
9. **Install Flooring Last:** Windlass flooring should be the last material installed into the structure except for the base molding. Covering the floor with paper while other trades are working can result in moisture damage to the flooring as well as denting and scratching of the material. Coverings over the flooring held in place by tapes can cause damage to the finish of the flooring.
10. **Cabinets, Furniture, and Heavy Objects:** Built-in cabinets and built-in furniture should be installed prior to the flooring. Do NOT install cabinets or fixed objects on top of the Windlass flooring. Do NOT place heavy furniture or other heavy objects on top of the flooring. Windlass flooring is made to free float on the subfloor. Installation of cabinets, other permanent built-ins, and heavy furniture or objects placed on top of the flooring can inhibit the ability of the floor to expand and contract which can lead to floor failure. Perimeter gluing is also not recommended for this same reason.
11. **Appliances:** Standard kitchen appliances, such as, refrigerators and stoves, are acceptable for placement on Windlass flooring. Use great care when moving appliances. It is highly recommended that you use a proper furniture dolly, air sled, 1/8” Masonite with glossy side down, or plastic glides which are designed for moving heavy appliances. Failure to follow these guidelines will result in damage to the floor.
12. **Acclimation:** Acclimation is not always needed. Windlass flooring must be installed where the temperature has been 60-75 degrees Fahrenheit and relative humidity within 30-50% at least 7 days prior to the installation. If the material has come from conditions outside these temperature and humidity parameters, the flooring material should be conditioned at the job site until the temperature of the product matches the indoor temperature. This can take 12-24 hours.
13. **Dimensional Stability:** Windlass flooring is more dimensionally stable than LVT or WPC products. You can install up to 80 feet in width or length. However, installations above 50 feet in length or width do require additional expansion joints.

## Pre-Installation Inspection

1. It is the responsibility of the owner and flooring installer to carefully conduct a quality inspection of all flooring prior to installation. Please ensure that material ordered is what has been received. Inspect for color, sheen, finish, and quality. If the product does not meet the acceptance of the owner or the installer, it should not be installed. We **require** the homeowner and installer to inspect the flooring in well-lighted conditions prior to installation. If there is a concern with the flooring, the decision not to proceed with the installation must be made within the first 10% of the total square footage or 100 square feet of flooring boxes opened, whichever is less. Boxes of flooring that are opened in excess of 10% of the total square footage or 100 square feet, (whichever is less) are not eligible for return including boxes left over from a completed job. Flooring that has been installed will be deemed to have been inspected and accepted by the owner and installer. Windlass flooring will not be responsible for flooring that has been installed with visible defects.
2. It is the responsibility of the owner and flooring installer to make sure that flooring is acclimated to proper temperature and humidity conditions. Climate control at the job site should be maintained with the room temperature between 60-75 degrees Fahrenheit and relative humidity within 30-50% before, during, and after installation. These conditions must be maintained for at least 7 days prior to installation.
3. Recognizing that vinyl flooring can be affected by varying levels of temperature and humidity within your structure, care should be taken to control them. It may be necessary to install exhaust fans and/or

humidifiers or dehumidifiers to help maintain levels of temperature and humidity. Uncontrolled humidity can lead to mold which can damage the structure and the flooring.

4. Prior to installing any flooring, the owner and installer must ensure that the jobsite and subfloor meets the requirements as set forth in these instructions. Windlass flooring will not be responsible for flooring failure due to unsatisfactory jobsite and/or subfloor conditions.

## **Subfloor Guidelines**

### 1. Acceptable Substrates:

- Concrete – On, Above or Below grade
  - Gypcrete/Lightweight Concrete – FLOATING INSTALLATION ONLY
  - Wood – Over Crawlspace, Basement, and Above grade
  - OSB and Subfloor rated plywood
  - Ceramic Tile – must be smooth, well-bonded, grout lines depth of less than 1/16”
  - Sheet Vinyl that is not cushioned or perimeter glued
- Note: Soft underlayment or soft substrates will diminish the product’s strength.
- CDX Underlayment Grade Plywood (over existing wood subfloor)
  - Existing Wood Floor (on wood subfloor glued or nailed) Existing wood floor MUST BE SOUND.

### 2. Unacceptable Substrate Types:

- Other floating floors (wood, vinyl, laminate)
- Perimeter glued resilient vinyl
- Rubber tiles on concrete
- Solid or engineered wood flooring on concrete
- Cushion Back Vinyl
- Rubber Tiles
- Carpet or Carpet Pad
- Sleeper Substrate Systems
- Lumber Subfloor
- Resilient floors installed below grade
- Cork
- Any additional sound/cushion/foam underlayment of any kind

## **Subfloor Preparation Wood:**

1. All subfloors must be structurally sound, dry, clean, smooth, and flat to a tolerance of 3/16” within a 10’ radius, 1/8” within a 6’ radius. If not level, sand down high spots and fill low spots with a Portland based leveling compound.
2. All subfloors must be free from any dust, paint, oil, solvents, adhesives, wax, and debris. Do not use solvent-based strippers to clean the subfloor as they could interfere with the bonding of the vapor barrier and adhesive systems.
3. Wood subfloor moisture testing must be conducted prior to installation. The top and bottom of the subfloor should vary by no more than 4% MC.
4. Wood subfloors with a crawlspace must have a minimum of 18” between the bottom of the joists and the surface of the ground. The ground must be covered with a 6 – 20 mil black polyethylene film that will serve as a vapor barrier. Plastic must be overlapped at joints by a minimum of 8” and sealed securely using a moisture resistant tape.

5. Subfloor must be firm. Maximum deflection between joists 1/16". When sagging or subfloor deflection of 1/16" or greater exists between joists, the floor should be sheeted with a 3/8" to 1/2" CD or better grade plywood to make the subfloor firmer.

### **Subfloor Preparation Concrete:**

1. All subfloors must be structurally sound, dry, clean, smooth, and flat to a tolerance of 3/16" within a 10' radius, 1/8" within a 6' radius.
2. All subfloors must be free from any dust, paint, oil, solvents, adhesives, wax, and debris. Do not use solvent-based strippers to clean the subfloor as they could interfere with the bonding of the vapor barrier and adhesive systems.
3. We require a 6-8 mil poly sheeting moisture barrier or the use of 2 coats of Wakol PU280 moisture barrier between concrete subfloor and luxury vinyl plank on and above grade. A 6-8 mil poly sheeting moisture barrier is required for installing below grade. Seams should be overlapped 12 inches and taped with a waterproof duct tape.
4. Concrete must be free of flaking, powder, drywall contamination, and grease.
5. All concrete subfloors must be at least 60 days old. The slab must be fully cured and the slab must be comprised of a Portland-based mix with a minimum 3000 PSI of compressive strength. A minimum 6 mil poly film is recommended between concrete and ground.
6. Concrete subfloors made of Portland based material, if need repair, must be patched using a quality, water resistant, non-shrinking Portland cement patch. Use Gypsum to patch Gypcrete. Be sure to fill all holes, dips, joints, and depressions.
7. Ceramic Tile and Sheet Vinyl must be well-bonded to subfloor, in good condition, clean, and level. Do not sand existing vinyl floors as they may contain asbestos. Ceramic Tile grout joints need to be filled with a Portland based cement patch.
8. Concrete moisture emissions should not exceed 5 pounds per 24hrs per 1,000 square feet on calcium chloride test or 85% on RH test.

### **Radiant Heat:**

1. Only hydronic radiant heat systems are approved for use with the Windlass flooring. Electric, Passive, and Surface-Channeled Radiant Heat systems are not approved.
2. A minimum of 3/4" must be maintained between the vinyl flooring and the tubing.
3. All radiant heat systems should not allow the surface temperature of the flooring to ever exceed 80°F.
4. Temperature sensors must be integrated into the system as a fail-safe to prevent excessive heat.
5. Radiant Heat in Lightweight Concrete Thermal Mass:  
Two to three weeks prior to installation, the temperature of the radiant heat system needs to be 70° F. After the 3 weeks is up, set the radiant heat system temperature to 80° F for 2-3 days. During this time the structure should be well-ventilated to prevent moisture build up. If this is not possible due to bad weather, then a dehumidifier should be used to keep moisture from building up within the structure.  
NOTE: Prior to installation, the lightweight concrete moisture content must not exceed 1.5% as measure with a Tramax Moisture Encounter Meter.
6. Radiant Heat in a Wood Subfloor:  
The hydronic radiant heat system must include an aluminum transfer sheet to ensure even distribution of the heat. Aluminum tube hanging systems must cover the entire distance between the joists on the bottom of the subfloor. Two to three weeks prior to installation, the temperature of the radiant heat system needs to be 70° F. After the 3 weeks is up, set the radiant heat system temperature to 80° F for 2-3 days. During this time the structure should be well-ventilated to prevent moisture build up. If this is not possible due to bad weather, then a dehumidifier should be used to keep moisture from building up within the structure.

## Starting the Installation:

After careful completion of the pre-inspection procedures and subfloor preparation, installation of your Windlass flooring can begin. Remember, Windlass flooring is designed to be installed using the floating method. A 6-8mil poly sheeting moisture barrier or 2 coats of Wakol PU280 moisture barrier between concrete subfloor and the Windlass flooring is required on and above grade. A 6-8 mil poly sheeting moisture barrier is required for installing below grade. This will help prevent the growth of mold and mildew.

1. Prior to installation, measure the length and the width of the room. Divide size of the room by the width of the plank to determine number of rows. Keep in mind that the first row may have to be trimmed to avoid the row on the opposite side being significantly narrower than the starting row. Select a starter wall.
2. Make sure material is properly acclimated as noted in general guidelines.
3. We recommend leaving a 5/16" – 13/32" expansion gap between the perimeter walls and any adjacent hardwood flooring. This is to allow for the expansion and contraction of your structure.
4. Always work from multiple boxes to get the best visual look possible.

## Installation Steps:

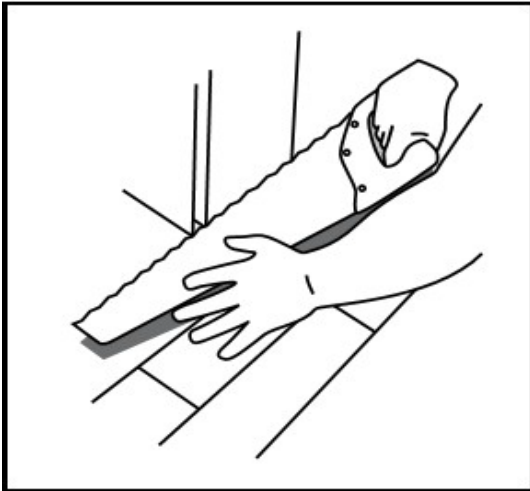

### 1. Under Cut All Door Jambs and Moldings:

Remove all shoe and base moldings to ensure adequate expansion space. Use scrap piece of flooring to establish height of cut. Remember to account for height of underlayment.

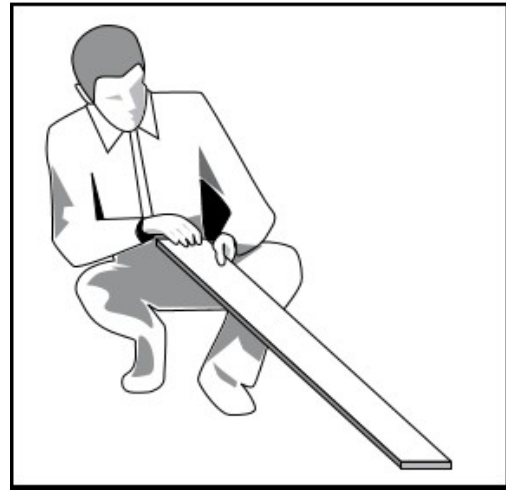

### 2. Visual Inspection of Planks

Inspect planks for any visual defects prior to installation. Verify that homeowner has seen product and has authorized installation of the flooring.

## Installation Steps:

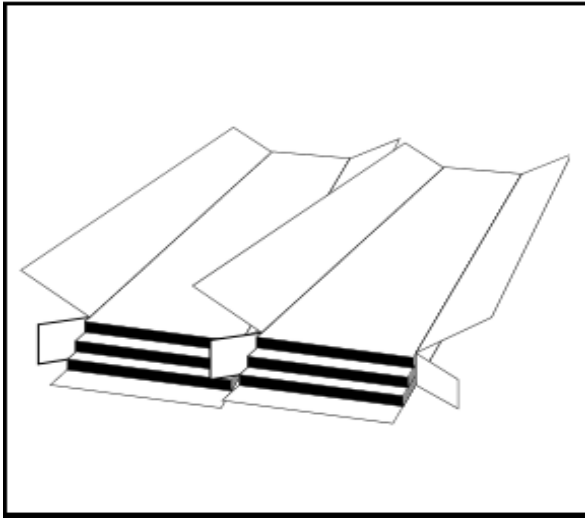

### 3. Open Multiple Boxes

Always work from multiple boxes to blend the planks throughout the installation. This will allow best visual look of the floor.

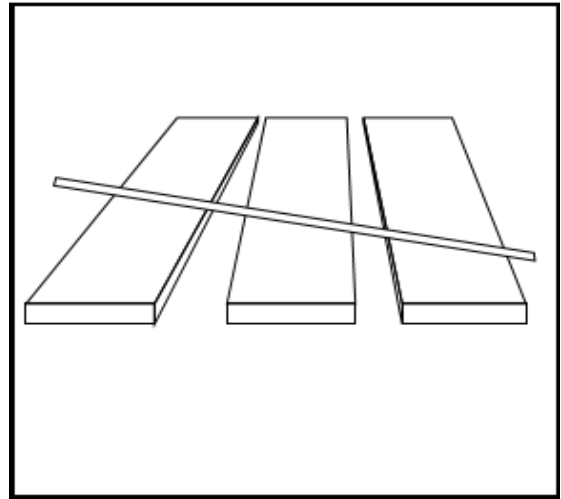

### 4. Blend Planks to Moldings

Before you begin installation, open multiple boxes and set aside the planks that blend best with the moldings.

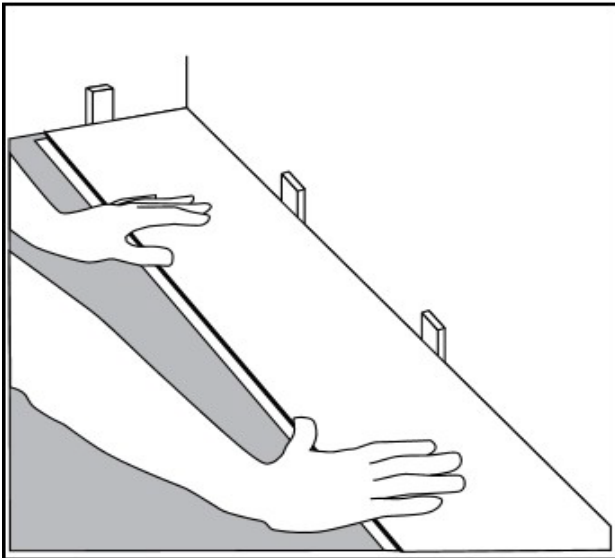

### 5. Select a Starter Wall

Select the longest wall in the room and work left to right, starting in the left-hand corner. For starting row use adjustable spacers against side and end walls to maintain  $5/16'' - 13/32''$  expansion space. Use spacers at both the side and the end of the rows. See #10.

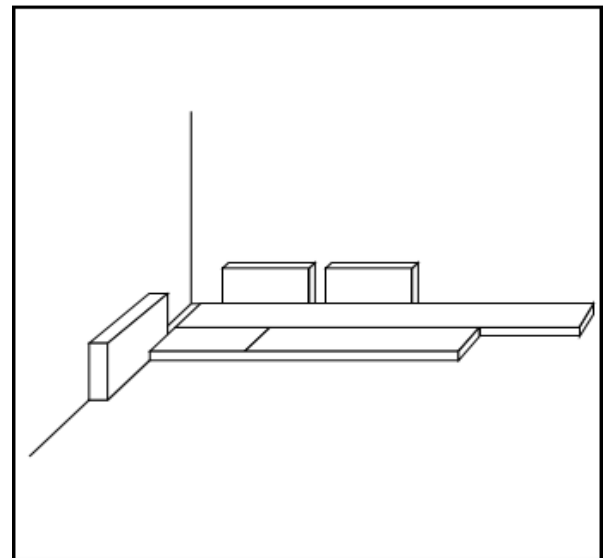

### 6. Starting Line

For starting row, cut blocks to use against side and end walls to maintain required expansion space. Use spacers at both side and end of rows. Use of adjustable spacers may be needed to keep a straight edge line.

## Installation Steps:

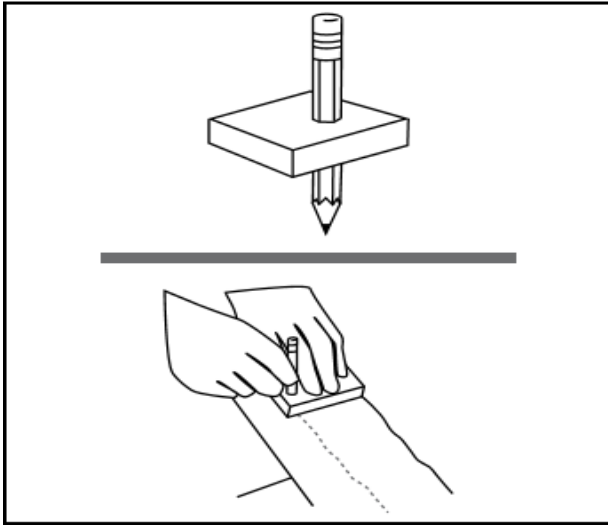

### 7. Irregular and Out of Square Walls

Scribe cut the 1<sup>st</sup> row to match variations in the wall. A scribe can be created by drilling a hole in a scrap piece of wood and inserting a pencil. The starting row can then be cut to compensate for an irregular wall or help to minimize the appearance of an out of square wall.

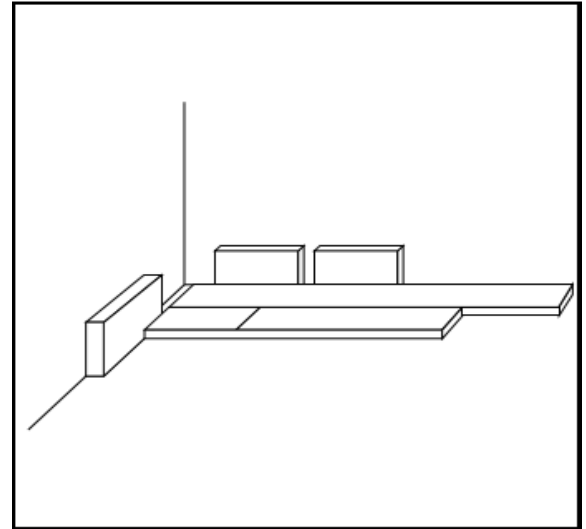

### 8. Expansion Space

Standard expansion space should be  $\frac{5}{16}$ " to  $\frac{13}{32}$ " and this will suffice for a floor that does not exceed 26 foot in span or width. Larger floors can be accommodated with an additional expansion space of  $\frac{1}{8}$ " for each additional 10 feet up to 80ft.

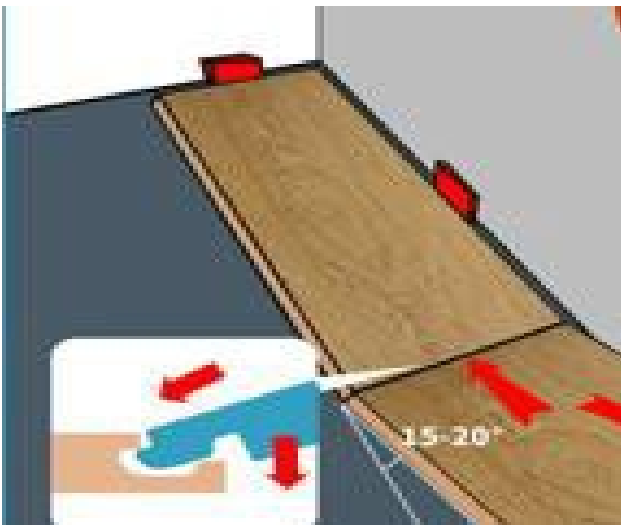

### 9. Lock in First Row End Joints

Place the first plank against the wall in the left corner of the room. Be sure spacers are in place. The first row of planks will be placed with the groove edge facing outward into the room.

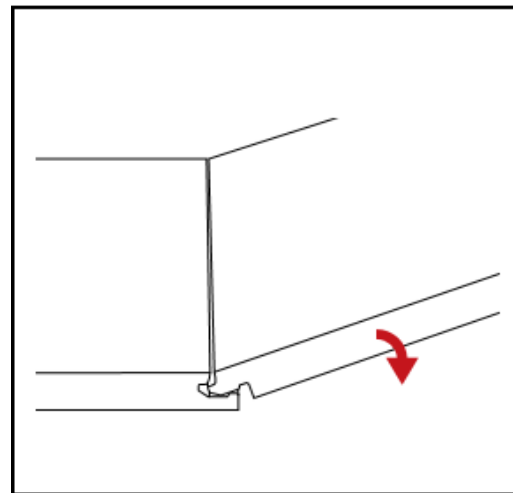

### 10. Angle / Angle Installation

Hold the new board at an angle of 15 to 20° to the previous installed board, insert the short tongue end of plank into groove. Continue the process for the remainder of the first row. To complete the first row, you may need to cut a plank.



## Installation Steps:

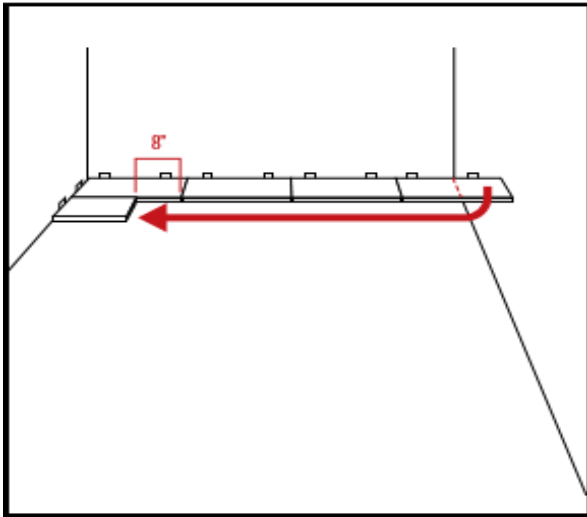

### 11. Second Row

Start the 2<sup>nd</sup> row by inserting the tongue of the long side of the plank into the long side of the groove on the first plank in the first row. End joint spacing must be no less than 8" apart from rows on either side throughout the entire floor. Watch carefully to avoid lining up too many of the end joints and setting an obvious pattern.



### 12. Second Row – Second Plank

Insert the tongue on the short side of the plank into the previously installed plank at a 30° angle. Align the plank so that the long side tongue is over the long side groove of the plank in the first row. Push the long side tongue into the groove by sliding along the short side seam. Lock the plank into place. The plank is properly engaged when there are no visible gaps and the planks are flush.

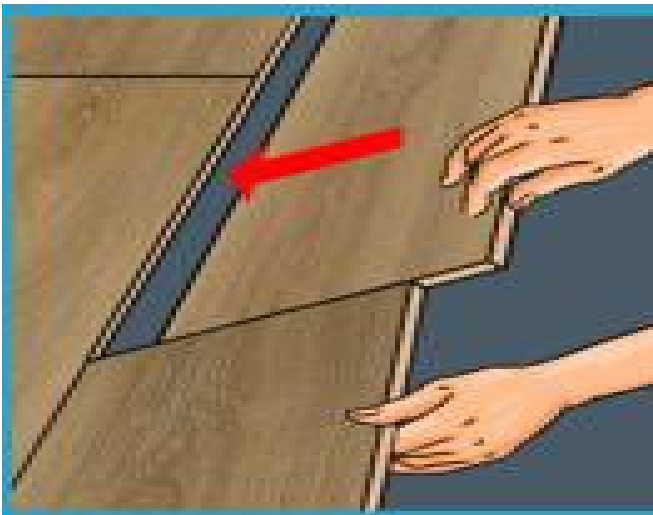

### 13. Placing Additional Planks

Continue to install remaining planks and rows. Remember that planks should be staggered, with at least 8" between end joints of adjacent planks.

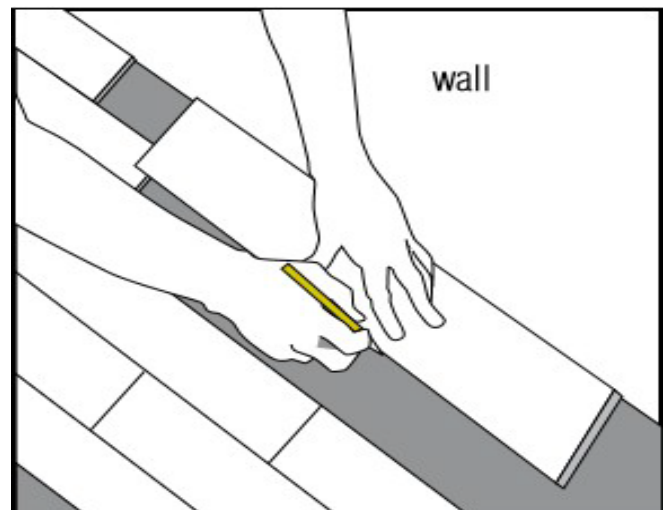

### 14. Last Row

When installing the last row, you may need to cut the width of the planks. Once install is complete, remove spacers and cover expansion space with trim pieces. Do **NOT** affix trim pieces to floor.

## Installation Steps:

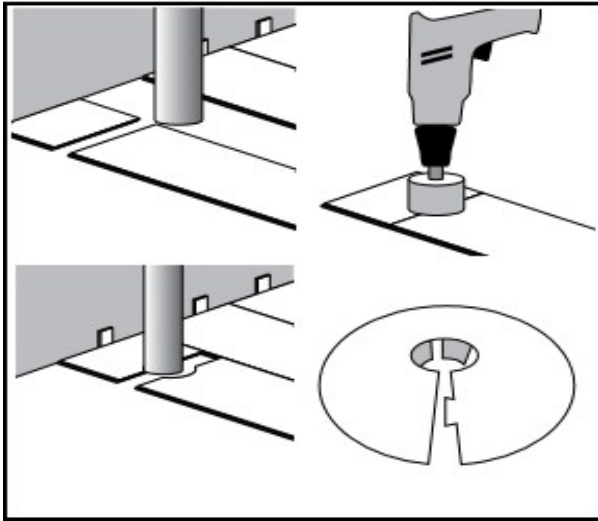

### 15. Installing Around Pipe

If the room has pipes or radiators, drill a hole large enough to fit around them with space for expansion.

## After Installation:

- After all planks have been installed, remove spacers from perimeter of room.
- Install any transition moldings. Do NOT fasten moldings to the floor.
- Quarter Round or Baseboard moldings must be large enough to cover 5/16" space. Do NOT fasten moldings through the flooring.
- Use a 1/8" Masonite sheet to cover and protect the top of the flooring when moving heavy furniture, appliances, or other heavy objects into place.
- Use proper floor protectors under the legs of furniture.